



SRV957
WALL MOUNT DISPLAY
PLATFORM SCALE

Operating and Service
Manual

TABLE OF CONTENTS

TABLE OF FIGURES.....	2
PACKING CHECKLIST – MODEL SRV957.....	3
ASSEMBLY.....	3
SYSTEM DESCRIPTION AND INTENDED USE.....	4
STORAGE AND TRANSPORTATION	6
CLEANING AND DISINFECTING	5
SPECIFICATIONS.....	6
DISPLAY FUNCTIONS	7
BASIC SYSTEM OPERATION.....	8
SYSTEM SETTINGS	9
REMOTE DISPLAY	10
CALIBRATION.....	10
TROUBLESHOOTING	12
WARRANTY.....	13
DISPLAY MOUNTING TEMPLATE.....	15

TABLE OF FIGURES

Figure 1: Display Screen	7
Figure 2: Settings Menu	9
Figure 3: Wi-Fi Icon	10
Figure 4: Calibration Table	11

PACKING CHECKLIST – Model SRV957 Wall Mount Display Platform Scale

√	DESCRIPTION	QUANTITY
	SCALE PLATFORM	1 ea.
	SCALE DISPLAY	1 ea.
	SIGNAL CABLE	1 ea.
	AC WALL POWER SUPPLY (MEDICAL GRADE)	1 ea.
	MOUNTING HARDWARE	1 ea.
	CERTIFICATE OF CALIBRATION	1 ea.
	MANUAL	1 ea.

ASSEMBLY

STEP 1: Unpack the scale system and check parts against the **PACKING CHECKLIST**. If there are any missing or damaged parts, call the Service Hotline at: 1-800-654-6360.

STEP 2: Determine installation location for scale and display, keeping in mind the display cable length is eight (8) feet and the display power cord length is five (5) feet. If desired, provisions for wall mount have been incorporated, and can be accomplished in the manner described below.

- A. The display should be installed by qualified personnel. The mounting hardware provided will cover most wall applications.
- B. Determine a position on the wall comfortable to the user. Mark the location of the two (2) mounting holes on the wall (holes are spaced 2.5” on center apart) using the template provided on page 15.
- C. Drill the two (2) pilot holes, no larger than ¼” diameter in the locations marked. Install the two (2) self-drilling screw anchors.
- D. Install the two (2) #8 x 1” flat head screws supplied, leaving approximately ¼” projecting from the wall.

STEP 3: Connect signal cable to the underside of the platform.

STEP 4: Place SRV957 scale platform on a flat, hard floor surface. Ensure all six feet of the scale are in contact with the floor and scale does not rock.

NOTE: Scale should not be placed on carpet or uneven floor surfaces as this may interfere with scale accuracy.

STEP 5: Connect the signal cable to the scale display, then connect the power cable to the scale display and plug power adapter into wall.

REPLACEMENT PARTS AND ACCESSORIES

Part #	Description
SE6000-14	Signal Cable
FBM1012000	Replacement Foot
FSAS751444BA	Replacement Foot Spacer
FR95X-AUX	Wireless Auxiliary Display (optional)
FRWR9HA2000	5V Medical Power Supply, USB Micro B

SYSTEM DESCRIPTION AND INTENDED USE

SYSTEM DESCRIPTION

The SRV957 Portable Platform Scale is a low profile design, 2 in. height, which allows the animal easy step access. The SRV957 Scale can be used in a fixed location or as a portable scale. The scale employs the latest in microprocessor and load cell technology to provide accurate and repeatable weight data. Six (6) identically matched transducers are strategically placed to ensure an accurate representation of the animal's weight.

The animal's weight is displayed on an LCD screen and can be viewed in either pounds or kilograms.

INTENDED USE

The SRV957 Portable Platform Scale is a lightweight portable scale designed for use as a weighing system for animals not exceeding 400 pounds or 182 kilograms, gross weight. Please read the following warnings to avoid injury to the animal or attendant.

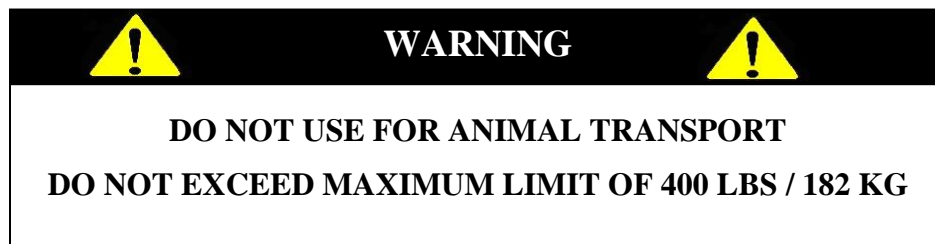

CLEANING and DISINFECTING

CLEANING

To clean the display / user interface:

- Wipe surface with clean soft cloth dampened with water and then dry with clean soft cloth.
- Do not spray liquid directly onto interface surfaces. Use only a damp cloth.

To clean platform / patient contact areas:

- Use a soft bristle brush with mild detergent and water when cleaning platform / patient contact areas. Pat dry with a clean cloth, or allow to air dry.
- Do not use abrasive materials to clean scale surface to prevent damage to the surface finish.

DISINFECTION

- Follow manufacturer's instruction on the proper use of commercially available disinfectants.
- Disinfectant solutions with 1% sodium hypochlorite or 70% isopropyl alcohol are suitable for display / user interface and other scale contact surfaces.

To disinfect the display / user interface:

- Use a soft cloth dampened with disinfectant or a damp disposable disinfectant cloth. Cloth cannot be dripping wet.
- After disinfecting, use a soft cloth dampened with clean water and dry with a soft clean cloth to prevent buildup of material on display.
- Do not spray liquid directly onto interface surfaces. Use only a damp cloth.

To disinfect platform / patient contact areas:

- Apply disinfectant solution to platform / patient contact areas.
- Patient contact area should remain wet with disinfectant solution for six minutes. Pat dry with a clean cloth, or allow to air dry.

WARNING: EXPOSURE TO EXCESSIVE LIQUID WILL DAMAGE USER INTERFACE KEYPAD.

WARNING: DO NOT USE PRESSURIZED WATER OR STEAM. THE SCALE SYSTEM CONTAINS ELECTRONIC COMPONENTS THAT MAY BE ADVERSELY AFFECTED BY EXPOSURE TO SUCH AN ENVIRONMENT.

STORAGE and TRANSPORTATION

STORAGE

To maintain proper operation of this instrument, storage and transport conditions should not vary outside the following conditions: Relative Humidity 0% to 85%, Ambient Temperature 14°F to 122°F (-10°C to +50°C).

TRANSPORTATION

The SRV957 Portable Platform Scale has four (4) recessed handles on the underside of the scale for easy portability.



SPECIFICATIONS

MAXIMUM WEIGHT CAPACITY	400 lb / 182 kg
PLATFORM SIZE	24 in x 48 in x 2 in (61 cm x 122 cm x 5 cm)
DISPLAY TYPE	4.3" TFT Color LCD / Resistive Touch
DISPLAY RESOLUTION	0.1 lb / 0.1 kg
ACCURACY	0.2% +/- 2 digits of displayed resolution for calibrated range
AUTO ZERO	One touch operation
AVERAGING	Automatic digital filter
POWER SUPPLY	AC Wall Power Supply (Medical Grade)
CALIBRATION	Calibration is traceable to NIST
OPERATING CONDITIONS	Normal operating conditions for this product: Ambient Temperature Range: 68°F to 85°F (20°C to 30°C), Relative Humidity Range: 0%-85%. Avoid exposure to high-pressure water or steam.
TRANSPORT and STORAGE	Storage and transport conditions should not vary outside the following conditions: Relative Humidity 0% to 85%, Ambient Temperature 14°F to 122°F (-10°C to +50°C). Remove batteries if storing longer than three (3) months.

DISPLAY FUNCTIONS



Figure 1: Display Screen

- WEIGH** The “**WEIGH**” button is used to clear the Recall memory and start a new weighing cycle.
- RECALL** The “**RECALL**” button is used to recall the last saved weight. Recalled weight reading will be displayed in orange. The “**RECALL**” button is only displayed in the **Auto Hold** weigh mode and when there is a weight value stored.
- ZERO** The “**ZERO**” button is used to zero the system before placing a patient onto the scale system and to erase the last saved weight. Ensure that nothing is in contact with the weighting surface during the procedure. The display will read “**0.0 LB**” (or “**KG**”).
- STABLE WEIGHT** The Stable Weight icon  blinks while actively weighing and then becomes steady when weight is stable.
- SETTINGS** The Settings icon  enters the system settings to view system information, pairing with the optional Auxiliary Display, perform calibration, or set weight units (**LB** or **KG**) as well as **Continuous** or **Auto Hold** weigh modes.
- QR CODE WEIGHT** Touching the displayed weight will switch the weight to a QR Code for easy scanning. Touch again to switch back.

BASIC SYSTEM OPERATION

TURNING SYSTEM ON

Make sure the scale is free and clear of any obstructions and all six feet are touching a level surface. Touch the screen to awaken from sleep mode and press the “**ZERO**” button. The display will read “**ZERO**” then display “**0.0**” when system is ready for weighing.

WEIGH

The “**WEIGH**” button is used to clear the “**RECALL**” memory and start a new weighing cycle.

RECALL

The “**RECALL**” button is used to recall the last stored weight. Recalled weight will be displayed until the display is zeroed again, or until the “**RECALL**” button is pressed again.

NOTE: The “**RECALL**” button is not displayed when there is no stored weight or when in **Continuous** weigh mode.

SLEEP MODE

With no weight on the platform, or after the display is zeroed, the display will “power down” to a sleep mode after 20 seconds. Touch the screen to wake it up.

CONTINUOUS WEIGH

With Continuous Weight enabled (in the System Settings menu), the **RECALL** mode will be disabled. “**RECALL**” button will not appear after a stable weight is seen.

AUTO HOLD

With Auto Hold enabled (in the System Settings menu), the **RECALL** mode will be enabled. When the system detects a stable weight, that value will be stored in system memory. This value can later be recalled by pressing the “**RECALL**” button with no weight on the platform.

UNITS

Weight Units can be changed in the System Settings menu. The system will remain in the same mode as last used unless manually changed.

SYSTEM SETTINGS

ACCESSING THE SETTINGS MENU

STEP 1: From the Home screen, press the System Settings button 

STEP 2: Enter password “12345”

STEP 3: Press the green checkmark 

SETTINGS

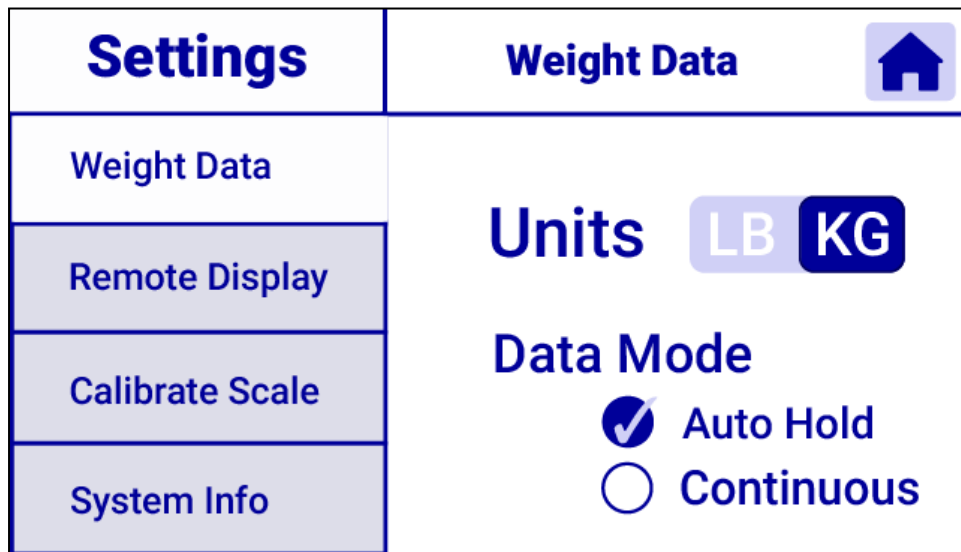



Figure 2: Settings Menu

- Weight Data** Weight units can be set to “LB” or “KG”
Display can be set to “Auto Hold” or “Continuous” weigh modes
- Remote Display** Main display can be paired to a remote display (sold separately)
See Remote Display section for pairing instructions
- Calibrate Scale** Recalibrate Scale platform
- System Info** View SRI Contact information, Model Number and Software Version information
- Home** Exit Settings Menu by pressing Home Icon 

WIRELESS AUXILIARY DISPLAY

NOTE: IF ORDERED SIMULTANEOUSLY, THE WIRELESS AUXILIARY DISPLAY WILL SHIP PAIRED TO THE PRIMARY DISPLAY. NO FURTHER ACTION IS NEEDED.

If the Wireless Auxiliary Display was purchased separately, follow the instructions below

TO PAIR A REMOTE DISPLAY:

STEP 1: Standing near Primary display, connect power cord to remote display

STEP 2: Access System Setting Menu and select “**Remote Display**”

STEP 3: Press the “**PAIR**” button on Wireless Auxiliary Display

STEP 4: Verify that Wi-Fi icon on Wireless Auxiliary Display is illuminated green

NOTE: A WIRELESS AUXILIARY DISPLAY CAN ONLY BE PAIRED TO ONE PRIMARY DISPLAY AT A TIME

If more than one SRV957 is in use, open the “**Remote Display**” menu on both the Wireless Auxiliary Display and the desired Primary Display. Verify matching “Primary MAC” addresses on both displays.

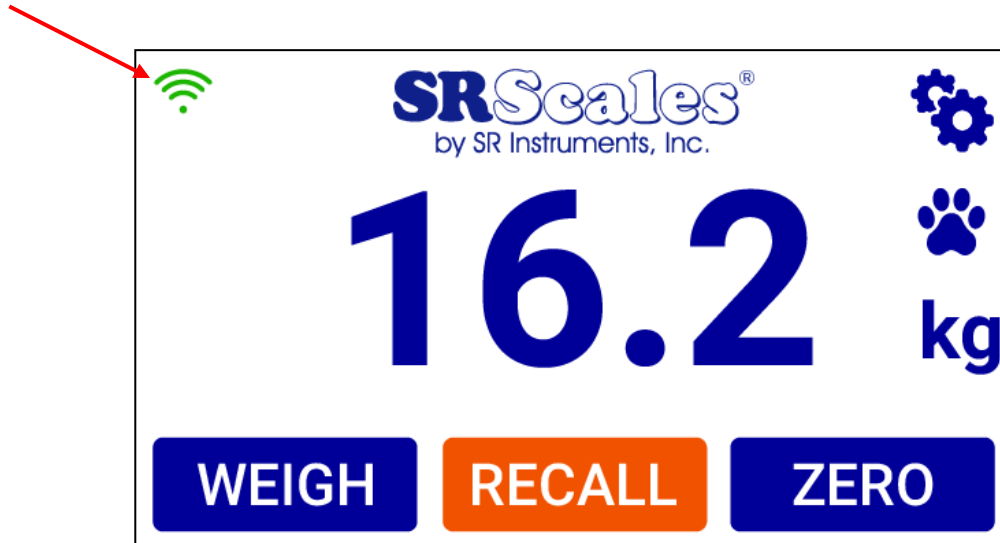

Figure 3: Wi-Fi Icon

CALIBRATION

NOTE: Ensure that nothing is in contact with the scale system during this procedure. Remove hands from the system when noting the displayed calibration results.

CHECKING CALIBRATION

STEP 1: Select known calibrated weights, traceable to NIST.

NOTE: DO NOT USE barbells or un-calibrated weights.



STEP 2: Zero the scale by pressing the **ZERO** button.

STEP 3: Place the calibrated weight on the scale. Wait for scale to stabilize; note scale reading.

STEP 4: Scale readings should be within Calibration Tolerance Table (Figure 4).



CALIBRATION TOLERANCE TABLE		
LOW LIMIT	APPLIED LOAD	HIGH LIMIT
99.8	100.0	100.2
199.6	200.0	200.4
299.4	300.0	300.6
399.2	400.0	400.8

Figure 4: Calibration Table

 **IMPORTANT** 

CALIBRATION CHECK Qualified service personnel only should perform this procedure. Load cells have no user serviceable components and should not be tampered with for any reason. Re-calibration is generally not required, but should be verified periodically to ensure accuracy. The recommendation for calibration check is at least once every 12 months, or as individual maintenance policy requires.

SETTING CALIBRATION

 **CAUTION** 

The integrated circuits and semiconductors on the printed circuit boards may be damaged by electrostatic discharge (ESD). Be sure to use proper handling precautions at all times.

NOTE: Ensure that nothing is in contact with the scale during this procedure and that all six (6) feet are touching a level surface. Remove hands from the system when noting the displayed calibration results. (Use known calibrated weight traceable to NIST)

STEP 1: Enter the System Settings menu and select “Calibrate Scale”.

STEP 2: Remove all weight from the platform and press “Done”.

STEP 3: Place the calibrated weight on the scale. Wait for scale to stabilize.

STEP 4: Press the “WEIGHT” field and enter the value of the weight on the platform.

STEP 5: Press the green checkmark  then press the “Save” button.

STEP 6: Display will automatically go to Home page with displayed weight. Remove weight, zero scale and then place weight on scale to verify calibration is correct.

TROUBLESHOOTING

SYMPTOM	REASON/CORRECTIVE ACTION
Display reads LOW	Ensure scale is on a level surface. Check to make sure all six feet are touching ground and ensure that nothing is touching bottom or sides of platform.
Display reads 0.0	Ensure Signal Cable is connected. There should be a weight difference between having the Signal Cable connected compared to being disconnected.
Display does not turn on	Power may be lost. Check circuit breaker switch and the power module.
For additional information or assistance, phone our Service Hotline: 1-800-654-6360 or e-mail: sri@srinstruments.com	

WARRANTY

TWO (2) YEAR LIMITED WARRANTY

Each **SR Scales**® system is manufactured with high quality components. SR Instruments, Inc. warrants that all new equipment will be free from defects in material or workmanship, under normal use and service, for a period of two (2) years from the date of purchase by the original purchaser. Normal wear and tear, injury by natural forces, user neglect, and purposeful destruction are not covered by this warranty. Warranty service must be performed by the factory or an authorized repair station. Service provided on equipment returned to the factory or authorized repair station includes labor to replace defective parts. Goods returned must be shipped with transportation and/or broker charges prepaid. SR Instruments, Inc.'s obligation is limited to replacement of parts that have been so returned and are disclosed to SR Instruments, Inc.'s satisfaction to be defective. The provisions of this warranty clause are in lieu of all other warranties, expressed or implied, and of all other obligations or liabilities on SR Instruments, Inc.'s part, and it neither assumes nor authorizes any other person to assume for SR Instruments, Inc. any other liabilities in connection with the sale of said articles. In no event shall SR Instruments, Inc. be liable for any subsequent or special damages. Any misuse, improper installation, or tampering, shall void this warranty.

DAMAGED SHIPMENTS

Title passes to purchaser upon delivery to Transportation Company. Purchaser should file any claims for shortage or damage with the delivery carrier and should refuse any shipment that has obvious external damage.

RETURN POLICY

All products being returned to SR Instruments, Inc. require a Return Goods Authorization number (RGA). To receive an RGA, call our Customer Service at 716-693-5977 ext 103 or toll-free in the USA and Canada at 800-654-6360 ext 103.

When inquiry is made, please supply model and serial numbers, purchase order and reason for return.

Generally, deleted, damaged, and outdated merchandise will not be accepted for credit. A minimum restocking charge of 15% will be assessed on return of current merchandise unless scale is returned because of SR error.

No returns will be accepted after 30 days.

All returns are to be shipped **FREIGHT PREPAID** to: SR Instruments, Inc., 600 Young Street, Tonawanda, NY 14150.

RESTOCKING FEE

- **15% fee** will be assessed on return of current merchandise
- **No fees** will be charged if the scale is returned because of an error on the part of SR Instruments, Inc.
- **No returns** accepted after 30 days.

NOTES

DISPLAY MOUNTING TEMPLATE

Determine installation location for scale and display, keeping in mind the display cable length is eight (8) feet. The display may lay flat on a desk or end table. If desired, provisions for wall mount have been incorporated, and can be accomplished in the manner described below.

- A. The display should be installed by qualified personnel. The mounting hardware provided will cover most wall applications.
- B. Determine a position on the wall comfortable to the user. Mark the location of the two (2) mounting holes on the wall (holes are spaced 2.5" on center apart) using the template provide below.
- C. Drill the two (2) pilot holes, no larger than ¼" diameter in the locations marked. Install the two (2) self-drilling screw anchors.
- D. Install the two (2) #8 x 1" flat head screws supplied, leaving approximately ¼" projecting from the wall.

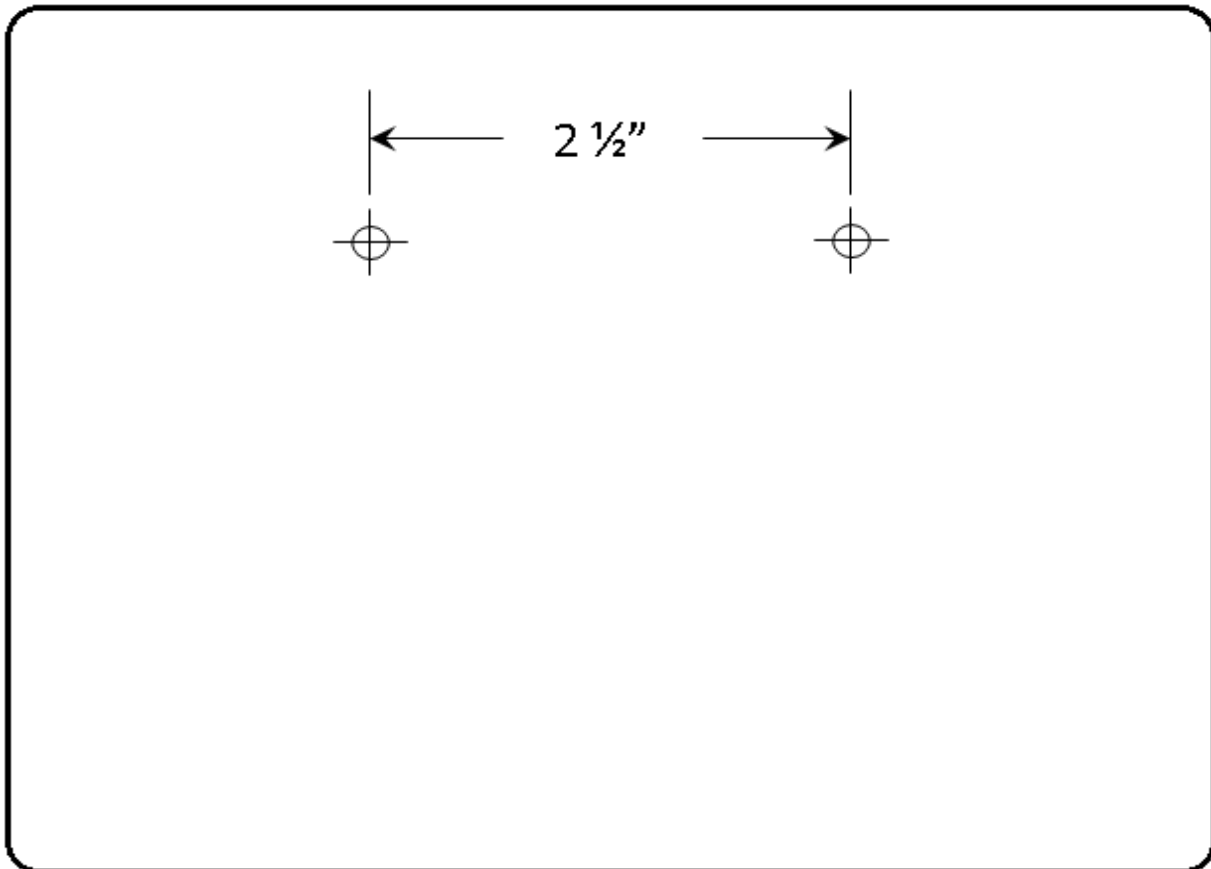



**Precision & Technology in
Perfect Balance™**